



Clear Vue Cyclones

CV1450/1700/1950 Installation Guide



Clear Vue
Cyclones

145 Nix Road
Liberty, SC 29657
888-299-0221

www.clearvuecyclones.com

Disclaimers & Warnings

WARNING: All persons, by purchasing a motorized dust collection system, motor, or individual parts from CLEAR VUE CYCLONES, or using these instructions which are provided as suggestions only, agree to the following disclaimer:

Installing and/or operating this motorized dust collection system, or use of individual parts, involves the risk of serious bodily injury or even death. The buyer and user accept total responsibility for any and all operation or use that may lead to personal injury, economic loss, social distress, other losses, costs and damages. Seller is not responsible for injuries and or damages of any kind resulting from operating this motorized dust collection system, motor, or use of individual parts or instructions.

All Rights Reserved, June 2022

Duplication of any part of this manual without expressed written permission from Bushey Enterprises, Inc. is prohibited.

IMPORTANT!

Minimum Recommended Ceiling Height

A minimum floor-to-ceiling height of 8 feet (96 inches) is required for a 20-gallon steel drum. The content of this manual is based upon the assembly of the system under an 8' ceiling.



If you have purchased a 30-gallon or a 40-gallon Steel Collection Drum from Clear Vue, additional ceiling height is required. You will need to account for this additional height during assembly.

- The 30-gallon steel drum requires a minimum ceiling height of 103".
- The 40-gallon steel drum requires a minimum ceiling height of 98".

If your ceiling is lower than this recommended height, please contact us at 888-299-0221 to discuss your alternate installation options.

Leaks

To maximize performance of your dust collection system, it will be imperative to check for leaks. Leaks on the suction side of the system will reduce the CFM (cubic feet per minute) performance levels. We recommend the sealing of all connections in your ducting.

Leaks in the collection drum or at the bottom of the cyclone are a major problem. Such leaks will cause an up-flow of air through the cyclone and prevent the dust from entering the collection drum. This will affect the separation efficiency of the cyclone and more dust will advance through to your filters, which may cause blockage and/or motor failure.

Leaks found anywhere after the dust reaches the blower may be blown back into your shop. This is a hazardous situation, and these leaks should be sealed immediately.

Testing for leaks can be done by performing a "smoke test". With any smoke-producing device (such as an incense stick), waft the smoke around the various seams of the system. Leaks in the ducting will cause the smoke to disperse. Leaks around the base of the cyclone will cause the smoke to be pulled in. Seal any leaks for optimal performance.

This page is intentionally left blank.

Table of Contents

Disclaimers & Warnings	1
Table of Contents	3
Dimensional Drawing	4
Cyclone Components	5
Specifications	6
Installation Tools	7
Box Contents	8
Installing Clear Vue Wall Mounting Brackets*	9
Constructing the Hanger Plate & Motor Assembly	10
Attaching the Impeller.....	12
Hanging the Motor/Impeller Assembly	14
Assembling the 90° Filter Transition (<i>filtered systems only</i>).....	15
Attaching the 90° Filter Transition (<i>filtered systems only</i>)	16
Attaching the Straight Exhaust Transition 8" (<i>non-filtered systems only</i>)	17
Attaching the Blower Housing to the Cyclone Body	18
Installing the Intake and Leveling the Cyclone	19
Assembling the Flangeless Filter Stack (<i>filtered systems only</i>)	20
Installing the Filter Stack Assembly (<i>filtered systems only</i>).....	21
Modifying the Collection Drum Lid.....	22
Installing the Collection Drum and Final Adjustments	23
Installing Your Power Box	24
Pairing Your Receiver and Remote	25
Electrical – Single-Phase Motors	25
Electrical – Three-Phase Motors	27
System Maintenance	28

Dimensional Drawing

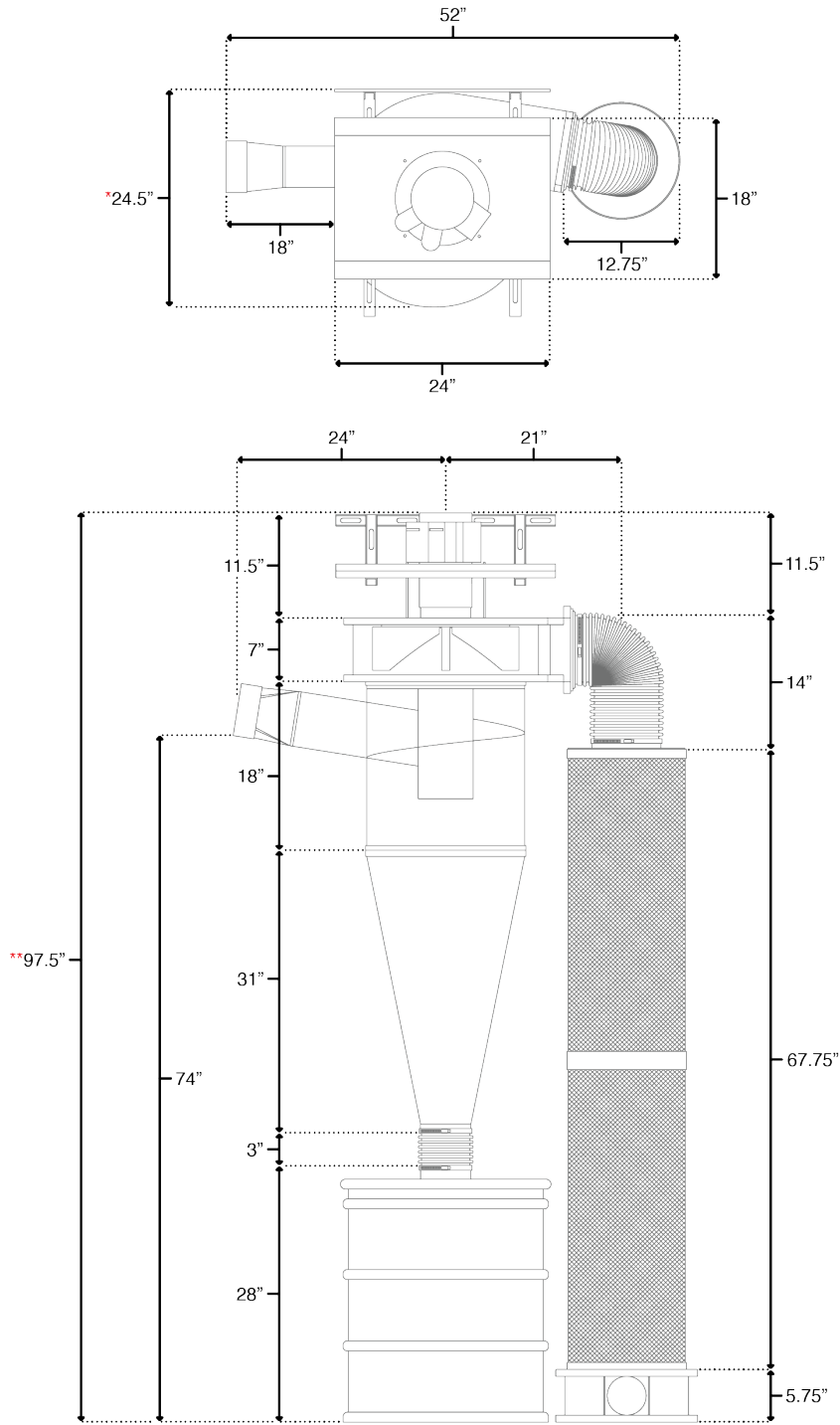

Rotation Options:

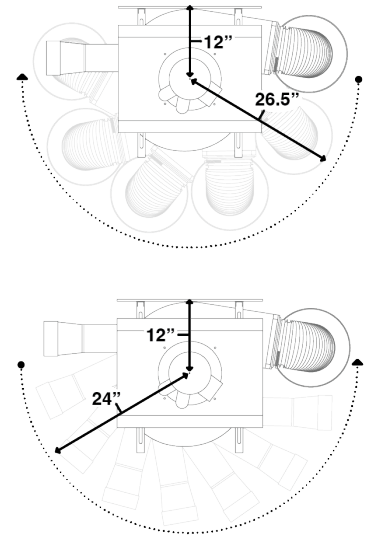

Filter stack and cyclone body can be rotated to any position in this 180° area.

This model is the Clear Unit with a 40 Gallon Barrel. Other barrel sizes will alter the overall height of the unit. Please visit our website for alternate system footprints: www.clearvuecyclones.com/instructional-media/

Collection Bin sold separately from system.

*The depth will vary based on the size and rotation of the Blower Housing.

**The minimum ceiling height with this variation is 98".

Cyclone Components

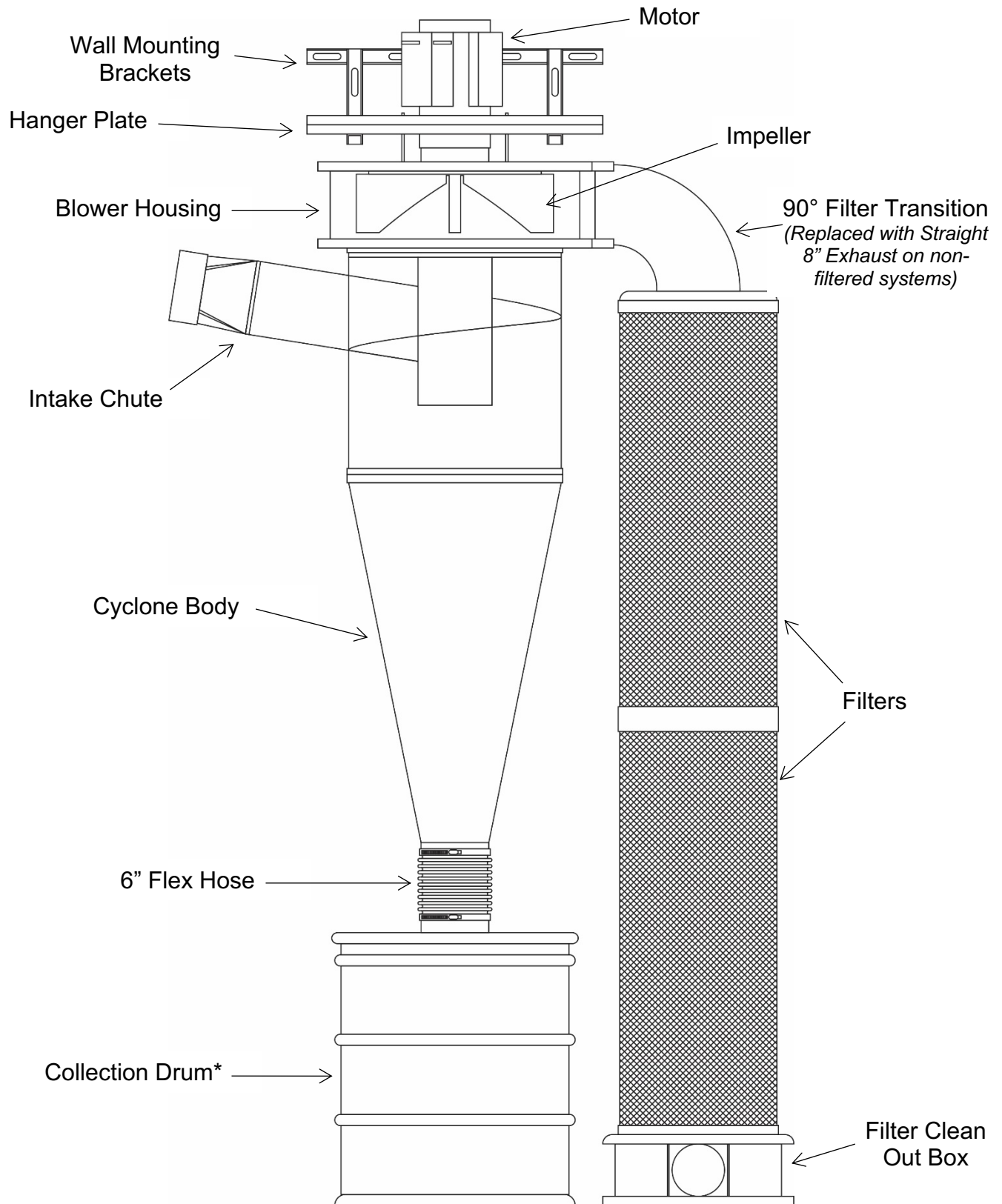

*Collection Bin sold separately from Clear Systems.

Specifications

	CV1450	CV1700	CV1950
System Performance	1,450 CFM at baseline static pressure of 2.25"	1,700 CFM at baseline static pressure of 2.25"	1,950 CFM at baseline static pressure of 2.25"
Footprint with Filters	52" x 21-1/2"	52" x 21-1/2"	52" x 21-1/2"
Footprint without Filters	45" x 21-1/2"	45" x 21-1/2"	45" x 21-1/2"
Minimum Height*	96"	96"	96"
Weight with Filters**	Single Phase – 164 lbs Three Phase – 214 lbs	Single Phase – 164 lbs Three Phase – 214 lbs	Single Phase – 164 lbs Three Phase – 214 lbs
Weight without Filters**	Single Phase – 130 lbs Three Phase – 180 lbs	Single Phase – 130 lbs Three Phase – 180 lbs	Single Phase – 130 lbs Three Phase – 180 lbs
Blower Assembly	15" steel, backward-inclined impeller	16" steel, backward-inclined impeller	16" steel, backward-inclined impeller
Cyclone Diameter	18"	18"	18"
Intake Size	6.25" ID (sized for 6" sewer & drain PVC – ASTM D2729 or SDR 35)	6.25" ID (sized for 6" sewer & drain PVC – ASTM D3034 or SDR 35)	8.5" ID (sized for 8" sewer & drain PVC – ASTM D3034 or SDR 35)
Intake Angle	Upward, 9°	Upward, 9°	Upward, 9°
Country of Origin	USA	USA	USA
Assembly Time	4-8 hours, with 2 people	4-8 hours, with 2 people	4-8 hours, with 2 people
Motor:			
Manufacturer	Baldor Electric	Baldor Electric	Baldor Electric
HP Rating	5 HP, non-TEC	5 HP, non-TEC	5 HP, non-TEC
Speed	Single Phase – 3,600 rpm Three Phase – 3,470 rpm	Single Phase – 3,600 rpm Three Phase – 3,470 rpm	Single Phase – 3,600 rpm Three Phase – 3,470 rpm
Current	Single Phase – 21.8 FLA at 230V Three Phase – 11.6 FLA at 230V 5.8 FLA at 460V	Single Phase – 21.8 FLA at 230V Three Phase – 11.6 FLA at 230V 5.8 FLA at 460V	Single Phase – 21.8 FLA at 230V Three Phase – 11.6 FLA at 230V 5.8 FLA at 460V
Auto Overload Protection	Yes	Yes	Yes
Electrical:			
Minimum Circuit Size	Single Phase – 30 amps Three Phase – 15 amps at 230V 10 amps at 460V	Single Phase – 30 amps Three Phase – 15 amps at 230V 10 amps at 460V	Single Phase – 30 amps Three Phase – 15 amps at 230V 10 amps at 460V
Minimum Recommended Wire Size	10 gauge	10 gauge	10 gauge
Filters:			
Manufacturer	Wynn Environmental	Wynn Environmental	Wynn Environmental
Model #	9B300NANO	9B300NANO	9B300NANO
Material	100% Nanofiber laminate	100% Nanofiber laminate	100% Nanofiber laminate
Area	300 sq ft each	300 sq ft each	300 sq ft each
Separation Efficiency	99.999% at 0.5 micron	99.999% at 0.5 micron	99.999% at 0.5 micron
MERV Rating	15	15	15
Dimensions	12.75" OD x 34" H x 8.4" ID	12.75" OD x 34" H x 8.4" ID	12.75" OD x 34" H x 8.4" ID

* Lower ceiling height installations available. Please contact Customer Service at 888-299-0221 for more details.

** System weight only. Collection drum not included in total weight of system.

Installation Tools

Items Needed for Installation:

- $\frac{9}{16}$ " Wrench
- $\frac{7}{16}$ " Wrench
- $\frac{3}{32}$ " Hex Key
- Drill
- Level
- Hammer
- 6' Ladder
- Tape Measure
- Box Cutter
- (1) tube of Caulk
 - *ALEX PLUS Acrylic Latex Caulk plus Silicone (color Crystal Clear) is recommended simply because it dries the clearest. Other brands/types may be used.*
- Collection Drum with Lid
 - Container must be round, airtight, and not subject to collapse.
 - See the section on *Modifying the Collection Drum Lid* for additional items that may be needed.
- $\frac{1}{2}$ " thick by 1" wide gasket or weather stripping (for tight seal on the lid of the Collection Drum).

**Wall Mounting Brackets and Filter Clean Out Box are available for purchase at www.clearvuecyclones.com.*

Box Contents

Cyclone Box:

- Cyclone body
- Intake chute
- 6" length of 6" flex hose
- (2) 6" flex hose clamps
- Straight Exhaust Transition for 8" Flex Hose (*non-filtered systems only*)

Materials Box:

- Blower Housing with motor plate
- Impeller
- Hanger Plate
- Wall Mounting Brackets with hardware kit
- 90° Transition sides and end plate (*filtered systems only*)
- 90° Filter Transition inner and outer plastic sides (*filtered systems only*)
- Hardware kit:
 - (4) $\frac{3}{8}$ " x 1- $\frac{1}{4}$ " bolts
 - (4) $\frac{3}{8}$ " flat washers
 - (4) $\frac{3}{8}$ " lock washer
 - (8) $\frac{5}{16}$ " x 1" rubber bushings
 - (4) #6-18 x $\frac{3}{8}$ " pan head screws
 - (6) #6 x 1- $\frac{5}{8}$ " sheet rock screws
 - (7) #6 x 1- $\frac{1}{4}$ " sheet rock screws
 - (8) $\frac{1}{4}$ "-20 lock washers
 - (28) $\frac{1}{4}$ "-20 flat washers
 - (24) $\frac{1}{4}$ "-20 nuts
 - (4) $\frac{1}{4}$ "-20 x 7" threaded rods
 - (4) $\frac{1}{4}$ "-20 x 1- $\frac{1}{2}$ " hex bolts
- Taper-lock bushing with (3) bolts

Motor Box:

- Baldor Electric Motor
 - Motor key will be taped to motor – *do not discard!*
 - *If the motor key is lost or missing, it is easiest to obtain from a Hardware store such as Ace, Lowe's, or Home Depot. The standard is $\frac{3}{16}$ " x $\frac{3}{16}$ " x 1- $\frac{1}{2}$ ".*

Filters (if applicable):

- *Shipped separately from Wynn Environmental for continental US orders*

Filter Clean Out Box: (*filtered systems only*)

- Filter Clean Out Box
- Filter Clamp and hardware

Electrical Box: (*Single Phase Systems Only*)

- *May be Shipped separately for continental US orders*
- Electrical junction box with relay
- 6' whip
- (1) remote



IMPORTANT

Check the contents of your boxes BEFORE ASSEMBLY to verify there was no damage sustained during shipment. Once a unit is assembled it cannot be returned. If there are any issues, please contact *Customer Service* at 888-299-0221.



Installing Clear Vue Wall Mounting Brackets*

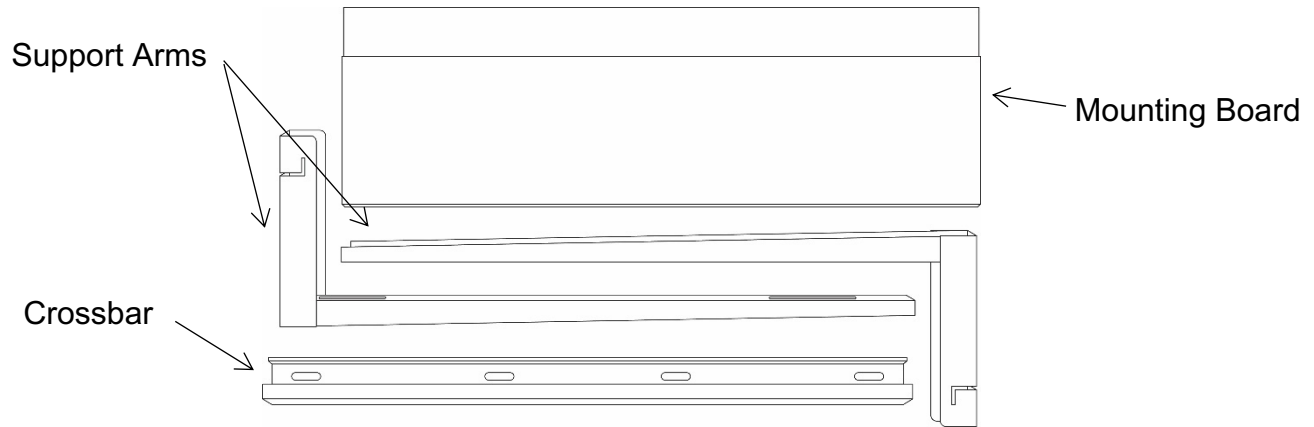

1. Measure where top of the crossbar will be mounted on the wall and mark accordingly. Our 8' installation requires the top edge of crossbar to be mounted at 95.5".



If your ceilings are higher than 8' and you are using a collection drum that is taller than 27", you will need to increase the mounting height of your brackets accordingly. The measurement does not need to be exact – a longer length of flex hose can be used between the base of the cyclone and collection drum to take up any excess height.

2. Attach the mounting board with the top flush to the 95.5". Use the appropriate wood screws (not included) to attach it to your wall studs.
 - a. Attach the crossbar to the recessed portion of the mounting board using $\frac{5}{16}$ " x 2" lag bolts (if you mount on the outer holes you may need to take out one of the bolts in order to attach the arms

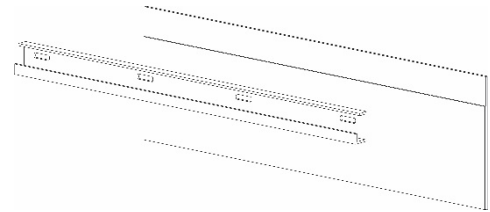

3. Slide support arms onto crossbar.
 - a. Position arms accordingly – the arms can be spaced so that the hanger plate is situated either lengthwise or widthwise

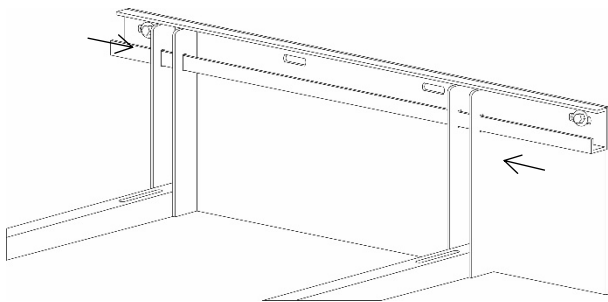

4. Mount crossbar to the studs of the wall, using a minimum of $\frac{5}{16}$ " x 2" lag bolts (not included).



If you choose to mount the crossbar to the wall first before attaching the arms, use the inner holes for mounting as the arms will not slide past the lag bolts. Once arms are attached, you can the fasten lag bolts in the outer set of holes.

Constructing the Hanger Plate & Motor Assembly

1. Assemble the threaded rod hardware:
 - a. Set up (4) threaded rods with the items shown. Leave about 2 to 2 ½" between item groups.

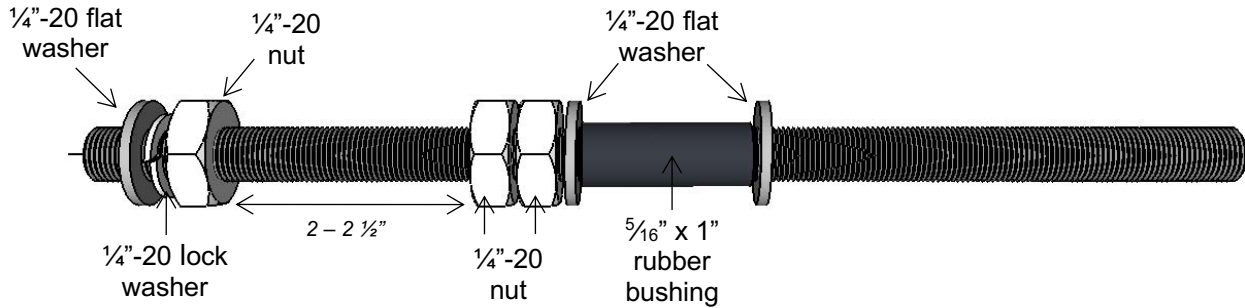

2. Locate the motor plate – it is the round disc secured to the top of the blower housing with (6) clips. Separate it from the blower housing by removing the (6) clips and associated hardware. Set these clips and hardware aside.

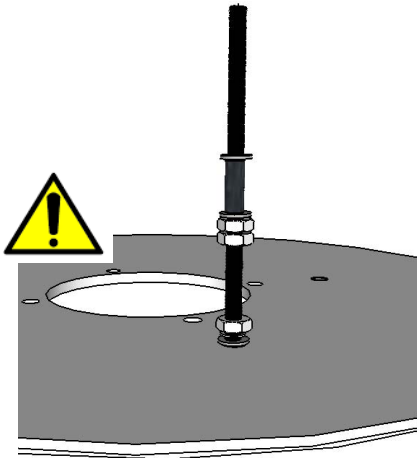

3. Insert (1) threaded rod assembly into each hole of the motor plate, with the hardware situated down.
 - a. Thread rod into T-nuts until they almost “bottom out”.

The T-nuts are installed on the rabbet side, which is facing down in the picture. Make sure the T-nuts are on the bottom side before inserting the threaded rod from the top.

- b. Once installed, the top washer should be approximately 4" above the motor plate.
 - c. Repeat for (3) remaining threaded rod assemblies.

4. Slide the hanger plate onto the threaded rod assemblies.

 *The strips on the hanger plate should be facing UP.*

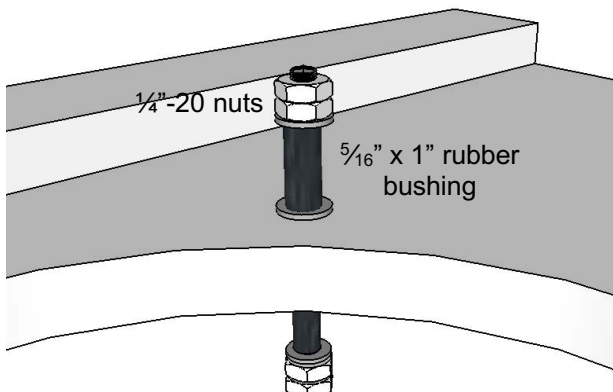

5. Install the remaining hardware above the hanger plate as pictured.

- a. Leave the ¼"-20 nuts above and below the hanger plate loose as they will be used to level the cyclone after it is hung.

6. Stand the motor on end, with the shaft facing up towards the ceiling.
7. Attach the motor to the hanger plate assembly:
 - a. Turn the hanger plate assembly over so that the hanger plate is down and set it on the motor. Be sure the holes on the motor plate align with those on the face of the motor.
8. Install (1) $\frac{3}{8}$ " x 1- $\frac{1}{4}$ " bolt through each of the holes on the motor plate into the holes on the face of the motor, using (1) $\frac{3}{8}$ " lock washer and (1) $\frac{3}{8}$ " flat washers per bolt.
9. Tighten each motor bolt securely.

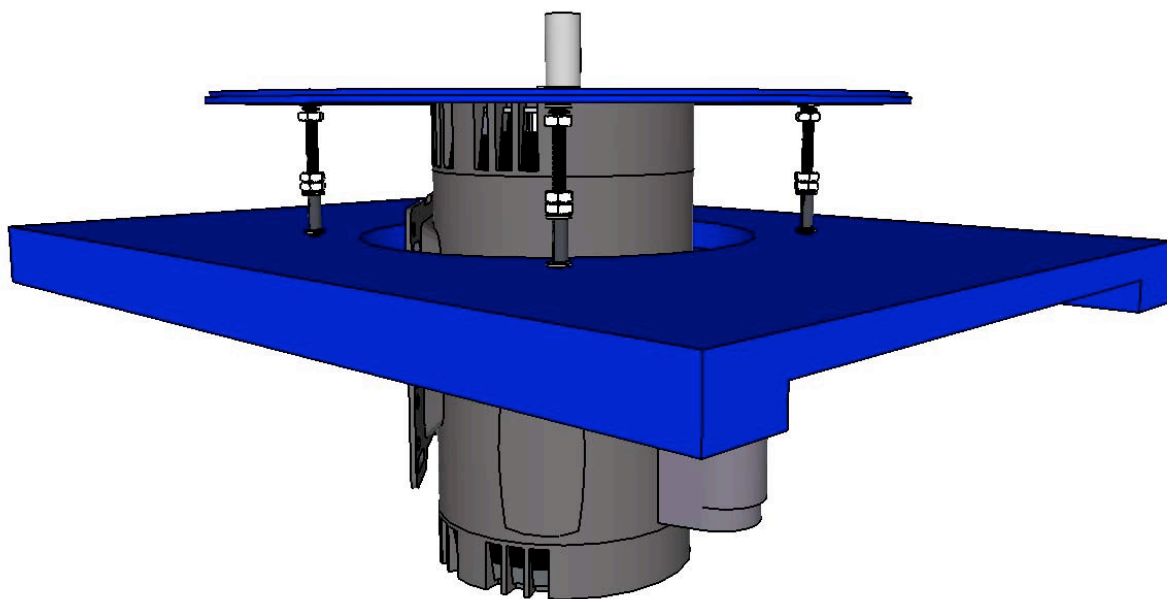
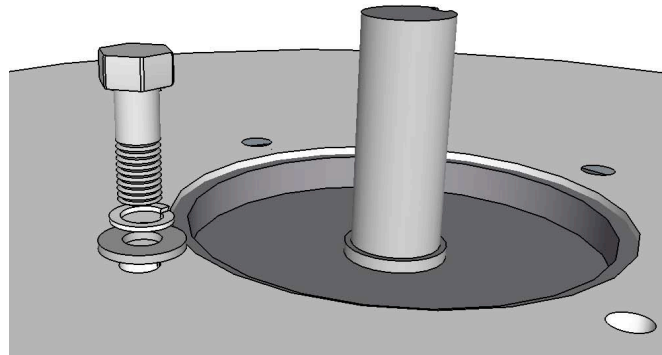

Completed Hanger Plate & Motor Assembly



Do NOT turn the motor on until the system is completely assembled, including the collection drum. Doing so may cause the circuit breaker to trip, physical damage to the system and/or bodily harm.

Attaching the Impeller



Improper installation of your impeller can lead to the impeller coming off during operation. Significant damage to your system and/or bodily harm can result. It is imperative that you read and follow these directions closely. Detailed assembly videos can be found under the Assembly Instruction section of our website at www.clearvuecyclones.com.

1. Locate the taper-lock bushing (and screws) inside the blower housing box.
2. Loosely attach the taper-lock bushing to the impeller:

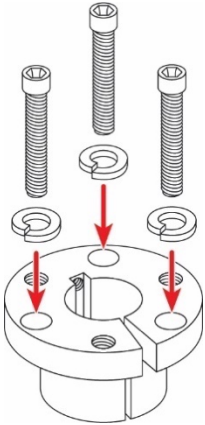

a. Insert the (3) taper-lock bolts into the **larger, non-threaded** holes in the taper-lock bushing.

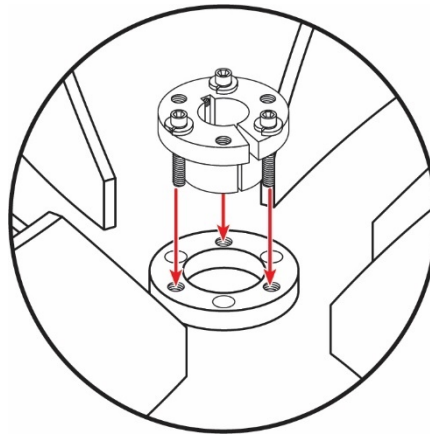

b. Slide the taper-lock into the hub in the center of the impeller with the wider side up, lining up the taper-lock bolts with the **threaded** holes on the impeller.



c. Finger-tighten the bolts to secure them in place.



Make sure the taper-lock bolts are inserted through the larger, non-threaded holes in the taper-lock bushing, into the threaded holes of the impeller. The alternate set of holes is used for impeller removal only.

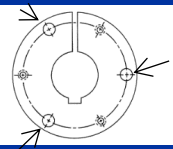

3. Position the impeller:
 - a. Slide the impeller onto the motor shaft, with the taper-lock bushing facing up.

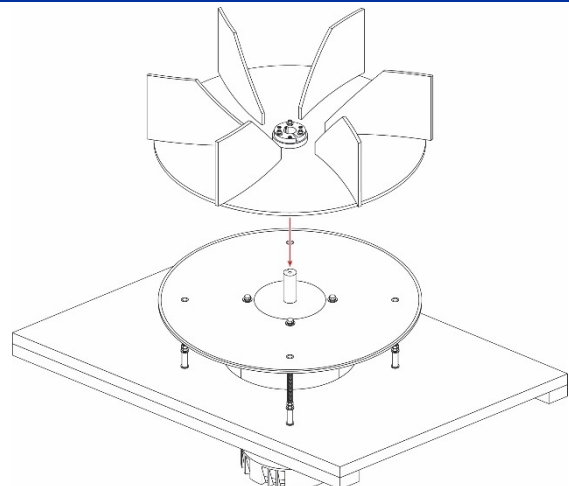

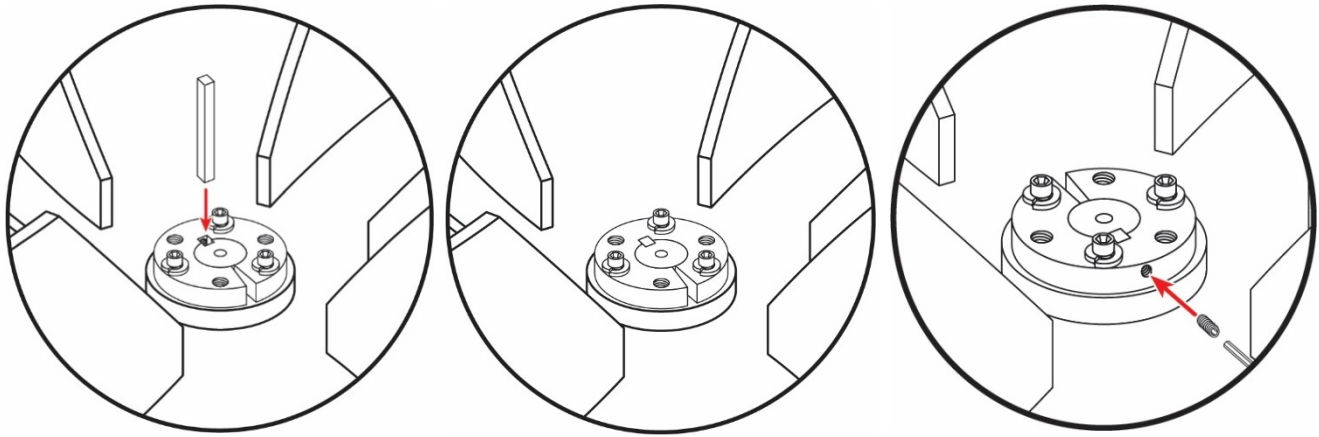

- b. Insert the motor key and lightly tighten the setscrew using a 2.5mm hex key until it cannot fall out.



For three phase motors, use the motor key that came inside the box with the taper-lock bushing. If there was a key taped to the motor, do not use it.

- a. For One Phase motors, lift the impeller so that the bushing is flush with the top of the motor shaft.
- b. For Three Phase motors, lift the impeller so that the bushing sits $\frac{1}{4}$ " below the top of the motor shaft.

4. Tighten the taper-lock bolts:

- a. Consecutively tighten each taper-lock bolt with a 4 mm hex key by a $\frac{1}{4}$ revolution, until they are all tight.



The tightening of each bolt will cause the subsequent bolts to feel as if they have loosened.

- b. **Repeat this process until each bolt is as tight as possible, without over-torquing the bolt.**

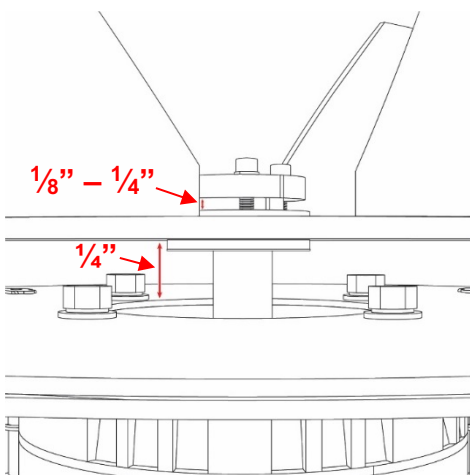
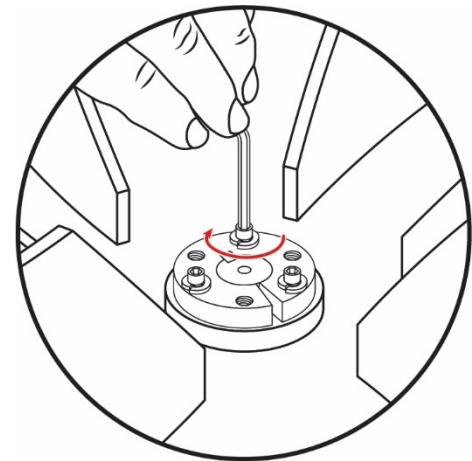

Upon completion, there should be a minimum of $\frac{1}{4}$ " clearance between the back of the impeller and the motor bolts intalled in the motor plate. There also may be up to a $\frac{1}{8}$ " - $\frac{1}{4}$ " gap between the taper-lock bushing and the impeller hub.

5. Firmly tighten the setscrew against the motor key using a 2.5 mm hex key.

Hanging the Motor/Impeller Assembly



If you purchased an Electrical Box with your system, it is recommended that you wire the 6' whip into the wiring box of the motor first, prior to hanging the motor/impeller assembly. Please refer to the Electrical Box instruction sheet for more detail.

1. Hang the motor/impeller assembly:
 - a. With the help of your installation partner, turn the motor/impeller assembly over so that the fins of the impeller are facing downward.
 - b. Rotate the assembly so that the wiring box on the motor will be accessible, once mounted.
 - b. Slide the assembly onto the Wall Mounting brackets – the hanger plate can be situated either lengthwise or widthwise, depending on installation.
2. The motor/impeller assembly will be secured to the Wall Mounting Brackets after the cyclone has been installed. This allows for the ability to move the motor/impeller assembly in or out a couple of inches to make installation of the cyclone easier.

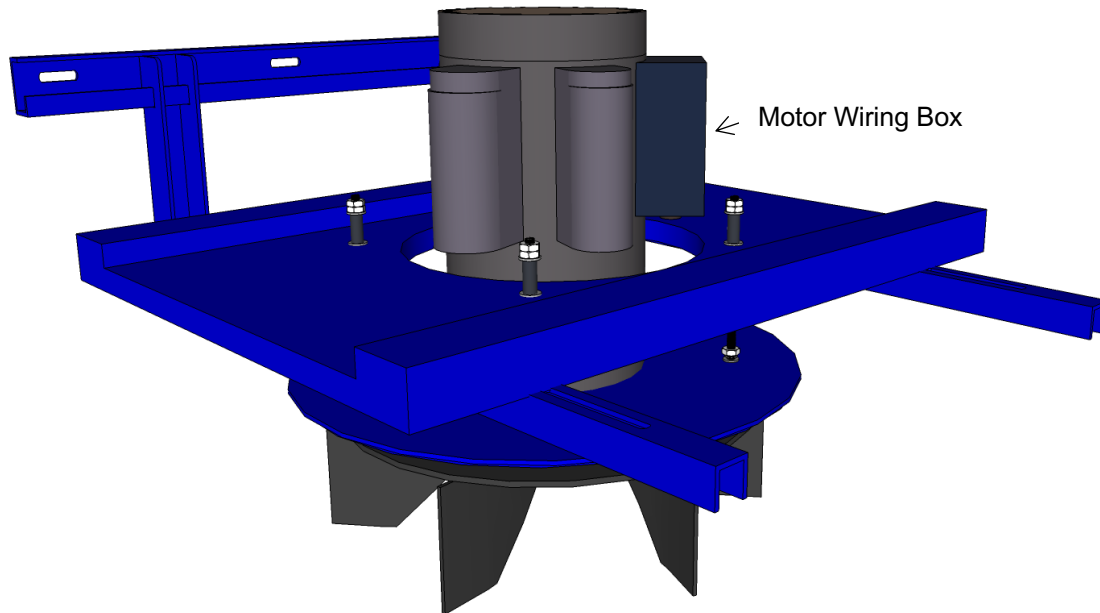

Do NOT turn the motor on until the system is completely assembled, including the collection drum. Doing so may cause the circuit breaker to trip, physical damage to the system and/or bodily harm.

Assembling the 90° Filter Transition *(filtered systems only)*

1. Begin by inserting the outer and inner plastic sides into the grooves of the side plates to form the transition.

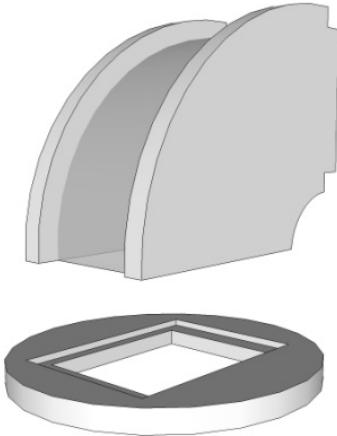
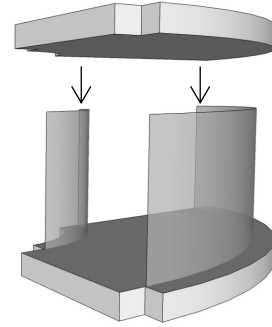

2. Slip the assembled sides of the transition into the slot of the round end plate
 - a. The straight ends of the two MDF side plates should be seated into the groove of end plate.

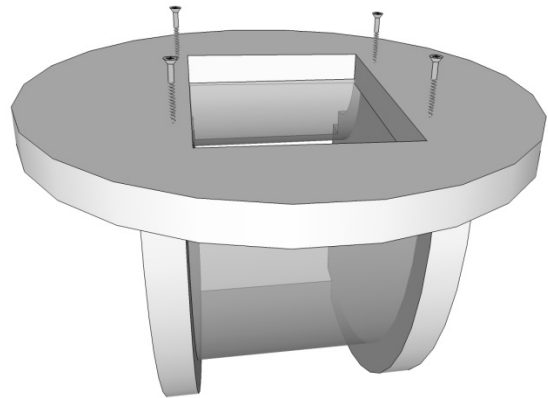

3. Secure the filter transition end plate:
 - a. Drill (4) small pilot holes in the bottom of the round end plate.
 - b. Attach the transition end plate using (4) #6 x 1-1/4" sheet rock screws.



Do not caulk the seams of the 90° Filter Transition until it is installed on the blower housing.

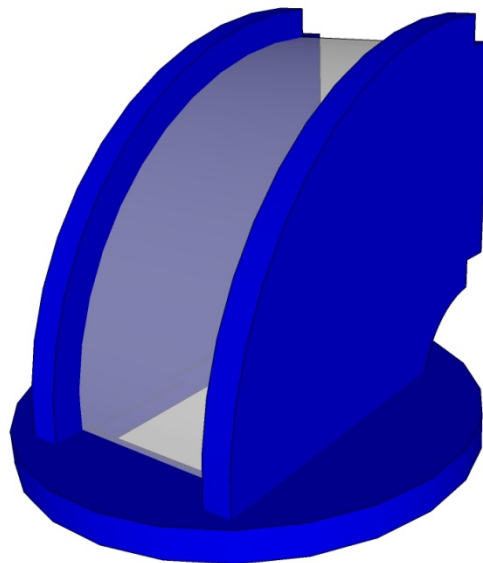

Attaching the 90° Filter Transition (*filtered systems only*)

1. Using a 7/16" wrench, loosen the (4) bolts closest to the rectangular opening on the blower housing and expand it slightly.
2. Slip the 90° filter transition onto the blower housing with the sides of the transition outside of the plastic wrapper of the blower.
 - a. Tighten the bolts on the blower housing to clamp the transition in place.

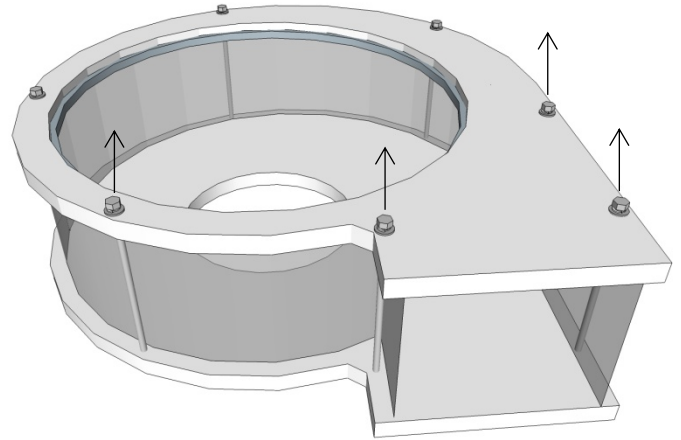

3. With the transition positioned, drill (2) holes through each side of the transition where it overlaps with the blower housing plastic wrapper, using a 5/16" bit.

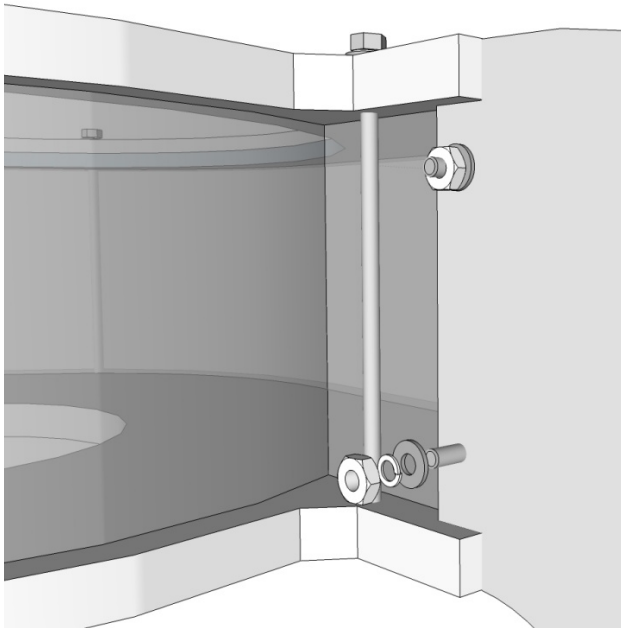

4. Insert a 1/4"-20 x 1-1/2" hex bolt into each hole from the inside, with the ends pointed towards the exterior of the assembly.
 - a. Secure the transition in place using a 1/4"-20 lock washer, 1/4"-20 flat washer and a 1/4"-20 nut.
 - b. Repeat for (3) remaining holes.
5. Center the two plastic sides of the transition between the blower housing and the transition end plate by sliding them up or down accordingly.

6. Caulk the seams of your blower housing (where plastic meets MDF), as well as where the 90° filter transition attaches to the blower housing, using clear silicone caulk. Be sure to cover all seams.



Sealing your blower housing and transition is very important. If there are any leaks, the unit will blow fine dust into your shop.



Do not remove the white block of wood mounted to the inside of your blower housing. This block counters the sound as the impeller blade passes by the larger opening of the blower housing, reducing noise.

Attaching the Straight Exhaust Transition 8" (non-filtered systems only)

1. Using a 7/16" wrench, loosen the (4) bolts closest to the rectangular opening on the blower housing and expand it slightly.
2. If the plastic sides of the blower housing exhaust are not pre-drilled:
 - a. Dry-fit the straight 8" exhaust transition to the blower housing.
 - b. Use the holes in the MDF sides of the exhaust transition as guides to pre-drill holes in the plastic sides of the blower housing exhaust.
3. Insert a 1/4"-20 x 1-1/2" hex bolt into each hole from the inside, with the ends pointed towards the exterior of the assembly.
 - a. Secure the transition in place using a 1/4"-20 lock washer, 1/4"-20 flat washer and a 1/4"-20 nut.
 - b. Repeat for (3) remaining holes.
4. The exhaust is sized for 8" flex hose (or any style of pipe with an 8" ID), used to duct to the final termination point outdoors.
7. Caulk the seams of your blower housing (where plastic meets MDF), as well as where the straight 8" exhaust attaches to the blower housing, using clear silicone caulk. Be sure to cover all seams.

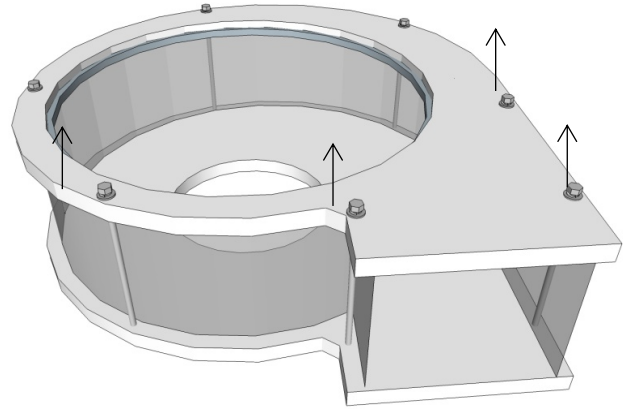

Sealing the exhaust is very important. If there are any leaks, the unit will blow fine dust into your shop.

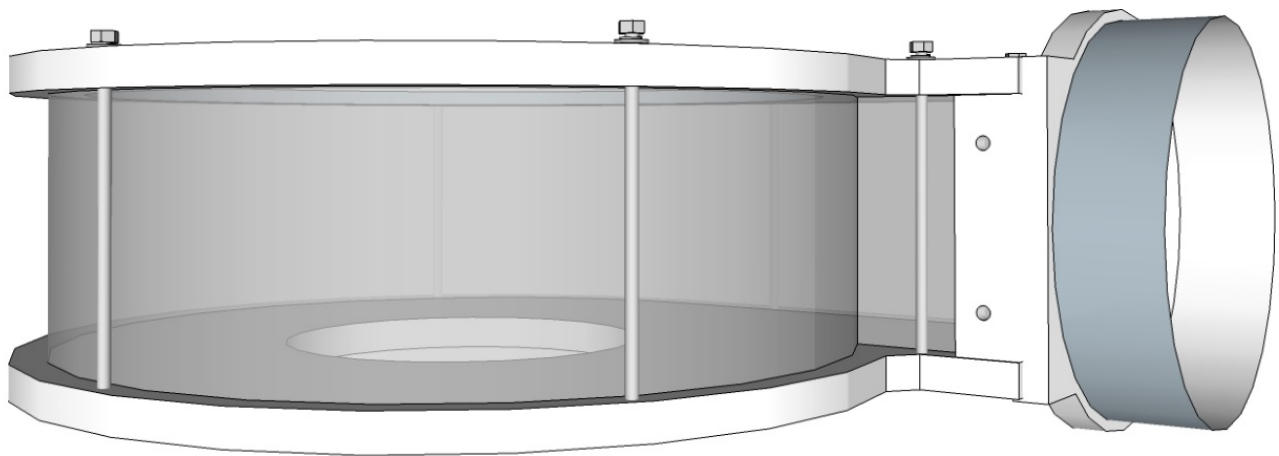

Do not remove the white block of wood mounted to the inside of your blower housing. This block counters the sound as the impeller blade passes by the larger opening of the blower housing, reducing noise.

Attaching the Blower Housing to the Cyclone Body

1. Place the cyclone body, right-side up and well-supported, in a drum or bin to keep the unit from tipping over. If a drum or bin is not available, the cyclone's shipping box can be shortened and used for support as well.
2. Set the blower housing on top of the cyclone.
Determine the desired orientation of the cyclone intake relative to the exhaust opening on the blower housing.



The position of the intake can be rotated in any direction with respect to the exhaust. This will not affect system performance in any way.

3. Secure the blower housing to the top of the cyclone body with (6) #6 x 1-5/8" sheet rock screws, using the pre-marked divots on the blower housing bottom as guides.
4. With the assistance of a helper, lift the cyclone body up so that the impeller is seated within the blower housing and the motor plate is aligned with the opening on the top of the blower housing.
 - a. If no help is available, remove the cyclone from the drum or bin used to secure it in step 1 and place a piece of plywood across the top of the container. Carefully position the cyclone body on top of the plywood and under the motor assembly, ensuring it does not tip, maintaining contact at all times. Slip a series of boards under the cyclone to lift the unit until the motor plate is correctly aligned with the top of the blower housing.
5. Secure the blower housing to the motor plate:
 - a. Reinstall the (6) clips removed earlier using using (1) 1/4"-20 x 1-1/2" hex bolt, (1) 1/4"-20 lock washer, and (1) 1/4"-20 flat washer per clip.
 - b. Leave the clips loose enough to allow for rotation of the cyclone.

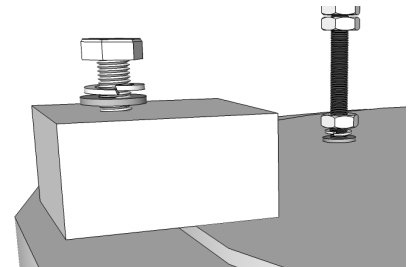
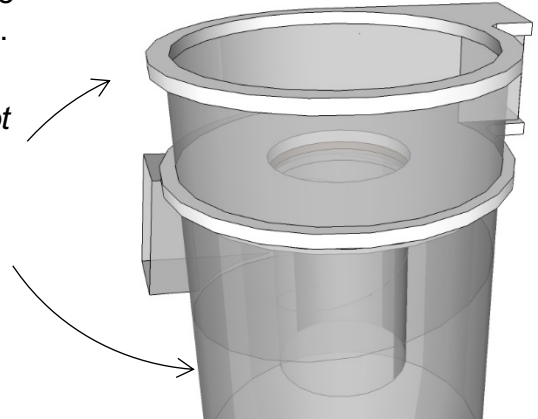

The motor plate will not sit flush with the top of the blower housing by design.



It is not necessary to seal the seam between the cyclone and blower housing, or the seam between the blower housing and motor plate, with silicone.

Installing the Intake and Leveling the Cyclone

1. Rotate the cyclone, if necessary, so the portion of the intake chute extending from the cyclone body is accessible.
2. Attach the intake transition to the cyclone by lining up the pre-drilled holes and inserting (4) #6-18 x $\frac{3}{8}$ " pan head screws.
3. Seal the seam between the chute and transition with silicone.
4. Rotate the cyclone, if necessary, into position and tighten the (6) clips on the top of the blower housing.

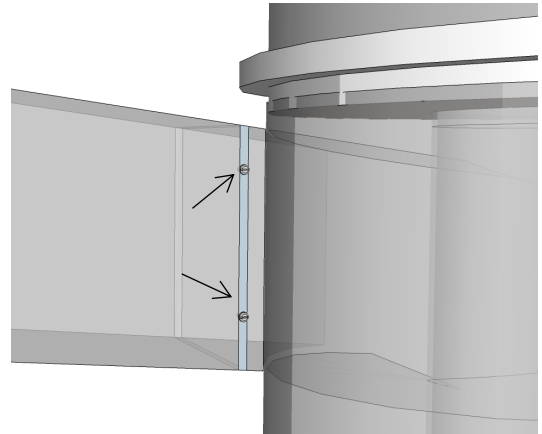

 *The position of the cyclone/blower housing assembly can be rotated in any direction. This will not affect system performance in any way.*

5. Place a level across the top of the blower housing to ensure that the cyclone is level.
 - a. To raise the system upward, tighten the $\frac{1}{4}$ "-20 nuts above the hanger plate, moving them down the threaded rod assembly towards the floor. Loosen the $\frac{1}{4}$ "-20 nuts below the hanger plate as needed.
 - b. To lower the system downward, loosen the $\frac{1}{4}$ "-20 nuts above the hanger plate, moving them up the threaded rod assembly towards the ceiling.

 *When finished, the cyclone should be within a $\frac{1}{4}$ " of being level in all directions.*

6. Tighten the $\frac{1}{4}$ "-20 nuts above and below the hanger plate so they are snug without causing the bushings to bulge.

Wonder why there's a hole in the side of your cyclone?

This hole allows for a small amount of air movement in the area above the inner ramp in order to prevent dust from accumulating over time.

Do not plug this hole!

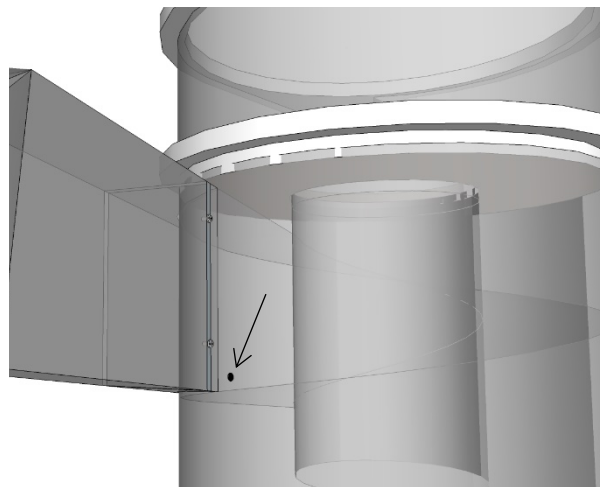

Assembling the Flangeless Filter Stack *(filtered systems only)*

1. Stack the two filters together, one on top of the other.
2. Run a bead of silicone caulk around the outside of the seam where the two filters meet.
3. Secure the band clamp:
 - a. Place a 1/4"-20 flat washer on the 1/4"-20 x 1" bolt.
 - b. Wrap the band clamp around the seam between the two filters.
 - c. Insert the 1/4"-20 x 1" bolt with the 1/4"-20 flat washer through the hole on the band clamp and tighten.
 - d. Place a 1/4"-20 wing nut on the hex bolt and tighten.
4. Place the stacked filters on top of the filter clean out box.
5. Run a bead of clear silicone caulk around the base of the filters, where they meet the filter clean out box, to ensure an airtight seal.
 - a. The silicone caulk will hold the filters securely in place and can be removed easily by cutting the bead with a razor knife.
6. If you purchased a filter clean out box from us, it will be caulked once the filter stack is installed.

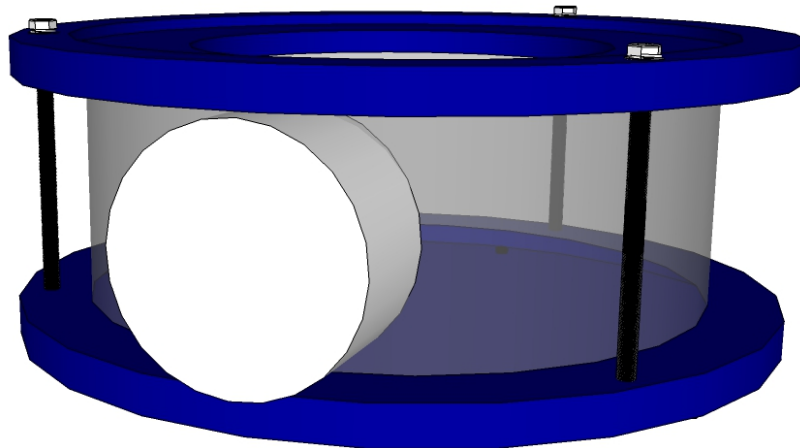
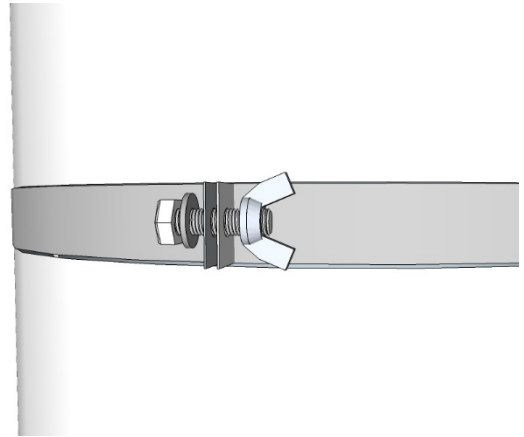

Filter Clean Out Box available for purchase at <https://www.clearvuecyclones.com/>

Installing the Filter Stack Assembly *(filtered systems only)*

1. Slide the filter stack assembly under the 90° filter transition. The fit should be exact.



If you are installing your system higher than 96", the filter stack assembly will need to be supported from below.

2. Secure the filter stack assembly to the 90° filter transition end plate:
 - a. Drill (3) pilot holes in the MDF and attach the filter stack assembly using (3) 1-1/4" #6 sheetrock screws.



These screws are not meant to be load-bearing in any way. They are intended to keep the connection secure if the filter stack is accidentally bumped.

- b. Run a bead of clear silicone caulk around the seam where the 90° filter transition end plate meets the top filter.
3. If you purchased a Filter Clean Out Box from us, caulk the seams where the PETG wrapper meets the MDF top and bottom.

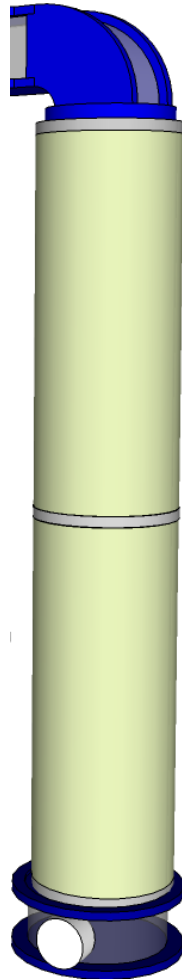

Completed Filter Stack Assembly

Modifying the Collection Drum Lid



The collection drum is not included with clear system purchase. **Any size drum can be used as long as it is round, airtight, not subject to collapse and as long as you have the ceiling height to support it.** Our standard 96" install allows for a drum no taller than 27" in height. Usually, this equates to a 30-gallon metal trash can available for purchase at your local hardware store. If you use a taller drum, you will need to raise the mounting height of the system.

A variety of steel drums may be purchased on our website. You may also contact Customer Service for more assistance.

Option 1: Metal Trash Can Lid

1. Cut a hole in the center of the metal lid:
 - a. Draw a 3" radius (6" diameter) circle, centered on the top of the lid using a fine point marker.
 - b. Draw a 2-³/₄" radius (5-¹/₂" diameter) circle centered inside of the larger circle.
 - c. Cut out the smaller circle using snips, jig saw or other appropriate tool.
2. Using pliers and snips, use the outer circle as a guide to bend a 1/4" lip in order to create a collar to attach the flex hose.
3. Use 1/2" thick by 1" wide gasket or weather stripping around the underside of the lid where it contacts the trash can for an airtight seal.
 - a. For further reinforcement, bungee cords may be stretched across the lid, on either side of the flex hose, and attached to the ends of the handles.

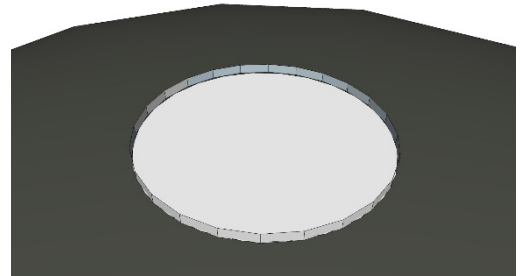

Option 2: Alternate Lid Types

If your drum does not support option 1, you can source a 6" HVAC starting collar (also called a take-off collar) from your local hardware store.

1. Cut a 6" hole in the center of the lid.
2. Mount the starting collar from the underside of the lid, up through the hole.
3. Seal the seams between the lid and collar, both on top and underneath, with clear silicone caulk.



HVAC starting collars can potentially add to the height of your collection drum. It is recommended to have at least 1" of distance between the base of the cyclone and top of the collar to allow for room to remove the lid. You may need to shorten the height of your collar accordingly.

Installing the Collection Drum and Final Adjustments

1. Attach the short length of 6" flex hose provided to the collar on the collection drum lid.
 - a. Secure the hose to the collar with a 6" flex hose clamp.
 - b. Caulk the hose from both sides of the lid to seal it in place.
2. Attach the lid to the cyclone:
 - a. Place a 6" flex hose clamp over the top of the flex hose. Make sure it is loose.
 - b. Install the lid by placing the 6" flex hose over the base of the cyclone.



The flex hose will be an extremely tight fit around the base of the cyclone. This is by design in order to make sure the connection is air tight. The flex hose can be made more pliable for installation by heating it with a hair dryer.



Make sure the notch at the base of the cyclone is fully covered by the flex hose.

- c. Tighten 6" flex hose clamp to secure flex hose to the base of the cyclone.
- d. Run a bead of clear silicone caulk around the seam at the top of the flex hose.



A longer length of flex hose may be used between the base of the cyclone and collection drum lid, if needed.

3. Before installing ducting use a C-Clamp to hold the unit in place until the ducting has been secured and the cyclone body is in its final position.
 - a. This is to ensure the unit does not fall off of the hanging brackets during installation and you are able to adjust the system before securing it properly.
4. Secure the hanger plate to the wall mounting brackets:
 - a. Pre-drill holes in the hanger plate.
 - b. Screw the hanger plate to the horizontal member of the wall mounting brackets:
 - i. If you purchased our Wall Hanging Brackets, hardware is provided.
 - ii. Alternatively use either 1-1/4" sheet rock screws or 1/4"-20 x 1-1/4" bolts (not included).

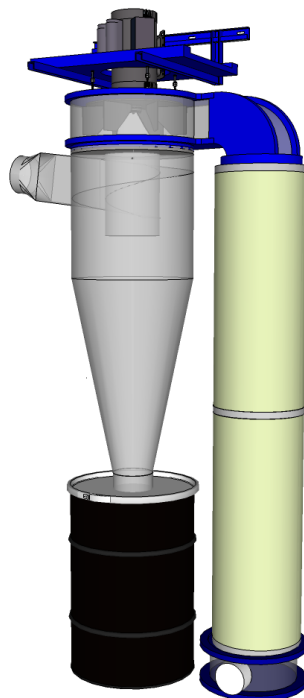

Installing Your Power Box

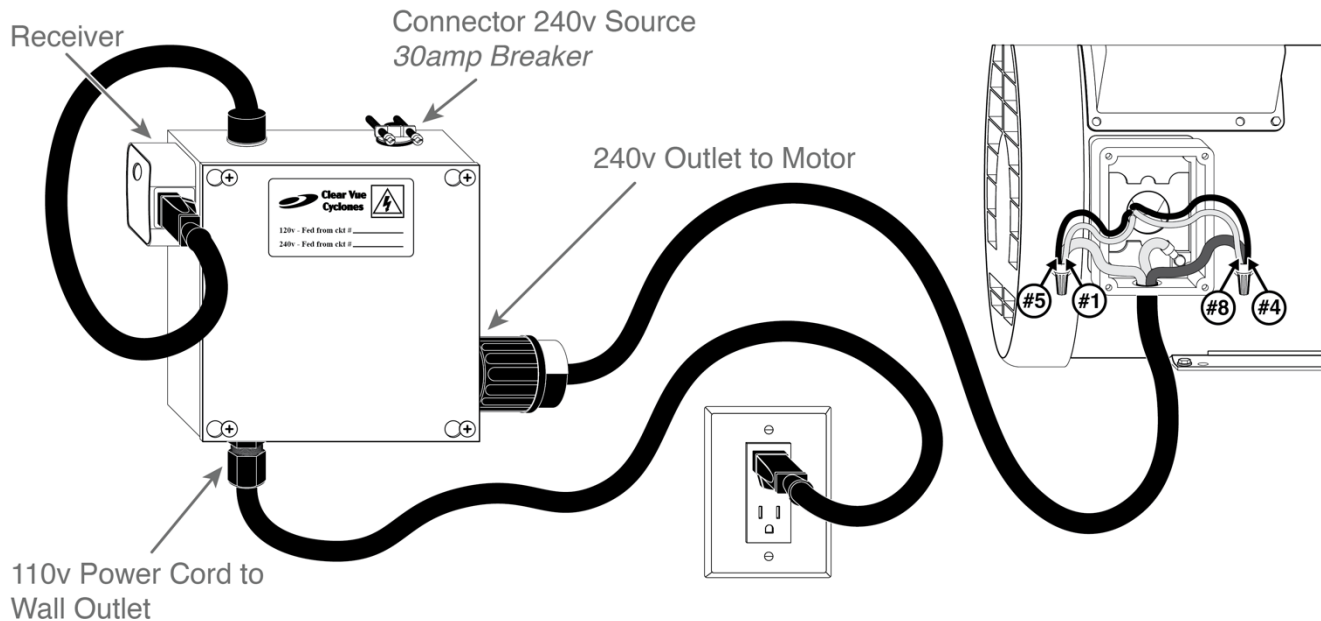

1. Wire the pigtail to the motor. For instructions, refer to the section on “Electrical – Single Phase Motors”.
 - a. The #1 and #5 wires on the motor connect to the black wire on the pigtail.
 - b. The #8 and #4 wires on the motor connect to the white wire on the pigtail.
 - c. The green wire on the pigtail is grounded to the motor.

You are wiring according to the Opposite Standard configuration graphic found on the body of the motor, referenced to the right.

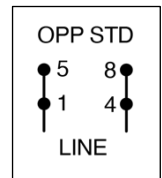

2. Open the cover of the Power Box by loosening the (4) screws that secure it in place and slide the cover up and then off.
3. Secure the Power Box to your wall using the (4) pre-drilled holes on the back of the box (hardware not included).
4. Hardwire the 240v power from your panel to the relay inside the box, using the knockout opening on the top of the box:
 - a. Secure the hot leads – one each – to each of the terminal pins on the top of the relay. Please note the leads are interchangeable.
 - b. Secure the ground wire into the top position on the grounding bar.
5. Install the 110v receiver:
 - a. Plug the receiver into the 110v outlet on the side of the box.
 - b. Plug the 110v power cord from the top of the box into the side of the receiver.
 - c. Plug the 110v power cord from the bottom to a separate 110v Outlet.
6. Plug the pigtail from your motor into the 3-wire 240v outlet on the side of the box.

Pairing Your Receiver and Remote

Your receiver and remote have come paired by the manufacturer prior to shipment. Pairing is saved for one year without power supply, but on occasion receivers/remotes do need to be paired again upon receipt.



Please note there is a small protective tab that must be removed from the battery compartment of the remote prior to use.

1. Clear previous pairings from the receiver memory:
 - a. Press and hold the power button on the receiver for 5 seconds until the LED indicator begins to flash slowly.
 - b. Press and hold the power button on the receiver for an additional 5 seconds until the LED indicator begins to flash rapidly.
 - c. Press the power button on the remote to confirm pairing has been removed.
2. Pairing the receiver and the remote:
 - a. Press and hold the power button on the receiver for 5 seconds until the LED indicator begins to flash slowly, indicating pairing mode has been activated.
 - b. Press the “ON” button, then “OFF” button on your remote to complete the pairing process.
3. Multiple remotes can be paired with the receiver by repeating steps 1 and 2 above.

Electrical – Single-Phase Motors



Clear Vue Cyclones highly recommends the use of a professional, licensed electrician to complete the wiring and any electrical work associated with this installation. Significant damage to your system and/or bodily harm can result



If you purchased our prewired Electrical Box, which gives you a remote start for your system, please refer to the assembly sheet included with this item.



Baldor recommends the use of wire lugs in lieu of wire nuts to secure all connections.

Once the motor is wired, the motor shaft and impeller blade should be turning **counter-clockwise when viewed from below** (i.e.: looking up at the impeller from the floor).

Note that our impellers are backward inclined, allowing our system to move high volumes of air at a variety of static pressures towards the filters or your exhaust. Each blade on the impeller has a slight “C” shape. When rotating correctly, the convex side of the blade will be hitting the air first. This rotation will match the yellow rotation sticker on your blower housing.

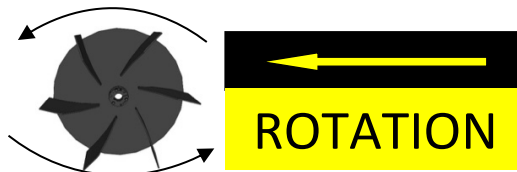

1. If you did not purchase the prewired Electrical Box and wish to use a 110v switch to power your system, we recommend the use of a Fasco H230B, 2 pole, 30 amp, 120v coil Contactor (relay). It can be purchased online at www.cshincorporated.com. Please use the following wiring diagram:

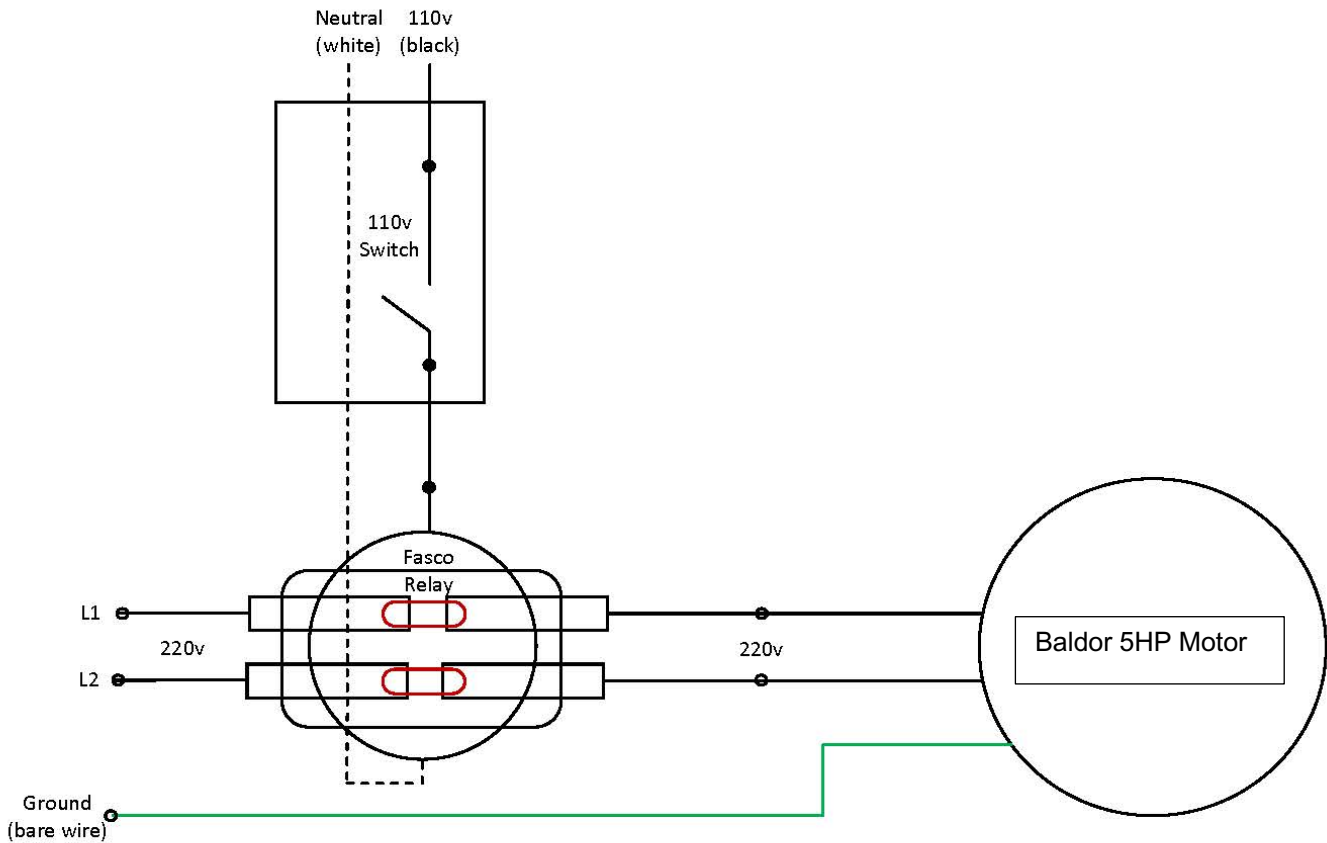

The Single Phase Baldor motor is not manufactured for repeated starts/stops more than 4 times per hour (stop only every 15 minutes). Repeated on/off quick cycles will cause damage to the motor and/or capacitors.

Electrical – Three-Phase Motors

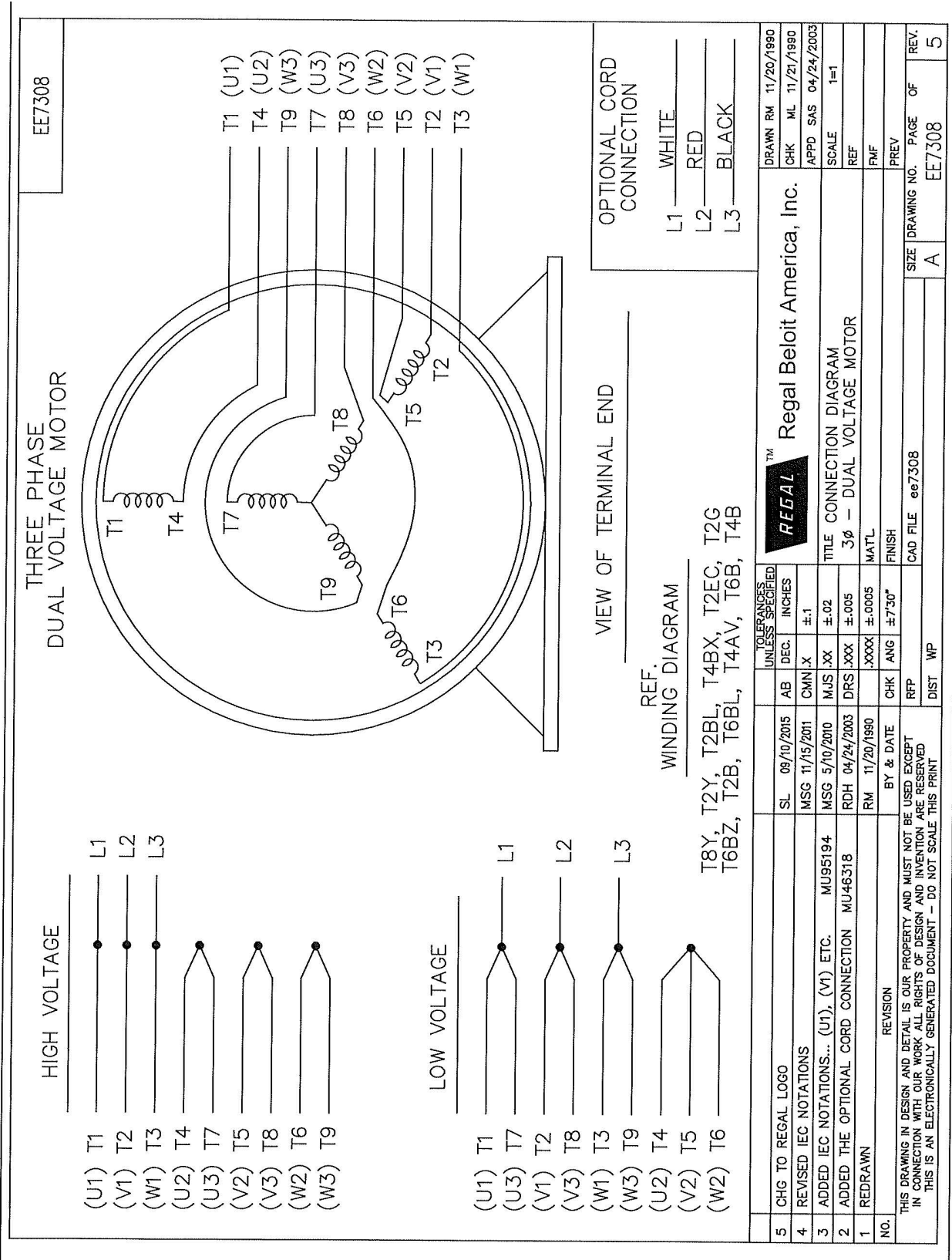

Baldor recommends the use of wire lugs in lieu of wire nuts to secure all connections.

System Maintenance

Filter Maintenance

1. The filters should be cleaned when the barrel is emptied.
2. The system should be OFF. Using the palms of your hands, aggressively slap down, top to bottom, on the outside. Fine particles fall into the Clean Out Box. Remove the dust particles with a shop vacuum or a dustpan.
3. Yearly, take the filters apart and bring them outside to thoroughly clean.
 - a. **Option 1:** Use two leaf blowers, one running through the center opening, the second blowing from the outside starting at the top and moving around the filter until very little dust continues to blow out the end of the filters.
 - b. **Option 2:** Use compressed air in short “puffs” from top to bottom in long vertical strokes using no more than 80 psi. After cleaning, reinstall and reseal

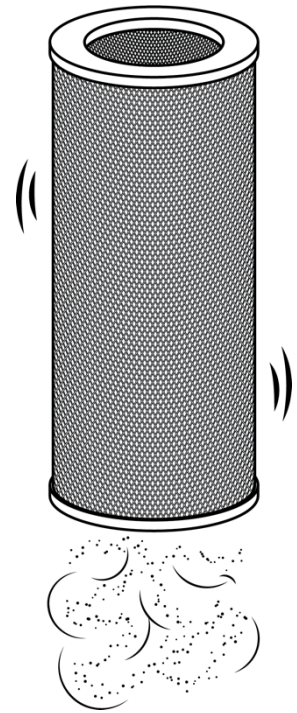

If you overfill your drum and there is material visible within the cone, there will be material in the filter stack requiring cleaning.

4. Overfilling the collection bin and planing lumber oftentimes leads to filter blockages.

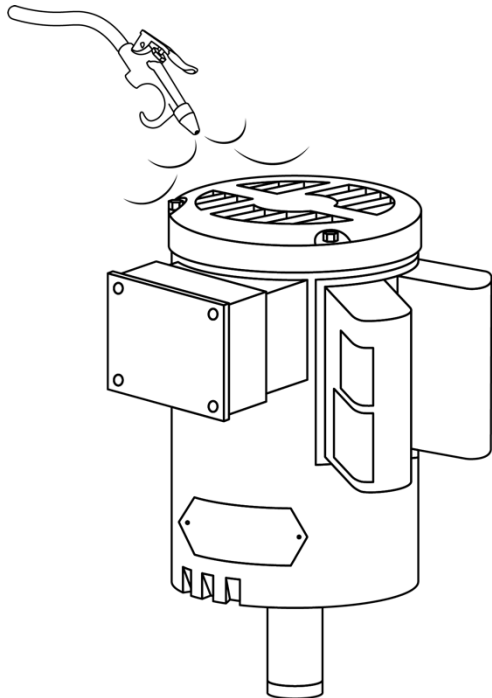

Motor Maintenance

1. Run the motor for AT LEAST 15 minutes per session. It takes approximately 10-15 minutes for the motor to cycle in the cool air that it needs to avoid overheating. The system should only be turned OFF/On 4 times per hour.
2. Upon shutting OFF, the motor may be restarted after the impeller is no longer running.



Constantly turning your motor OFF and ON can lead to lasting damage due to overheating.

3. At least every 6 months blow compressed air through the motor vents to keep the dust out of it and maintain proper airflow.